



IT IS THE MANUFACTURERS OPINION AND INTENT THAT THE USE AND LAYOUT OF THESE COMPONENTS CONFORM WITH THE AMERICAN SOCIETY FOR TESTING AND MATERIALS (ASTM) STANDARD ASTM F1487

THIS PLAY AREA & PLAY EQUIPMENT IS DESIGNED FOR AGES 5-12 YEARS UNLESS OTHERWISE NOTED ON PLAN.

IT IS THE MANUFACTURERS OPINION THAT THIS PLAY AREA DOES CONFORM TO THE A.D.A. ACCESSIBILITY STANDARDS, ASSUMING AN ACCESSIBLE PROTECTIVE SURFACING IS PROVIDED, AS INDICATED, OR WITHIN THE ENTIRE USE ZONE.

THIS CONCEPTUAL PLAN WAS BASED ON INFORMATION AVAILABLE TO US. PRIOR TO CONSTRUCTION, DETAILED SITE INFORMATION INCLUDING SITE DIMENSIONS, TOPOGRAPHY, EXISTING UTILITIES, SOIL CONDITIONS, AND DRAINAGE SOLUTIONS SHOULD BE OBTAINED, EVALUATED, & UTILIZED IN THE FINAL DESIGN. PLEASE VERIFY ALL DIMENSIONS OF PLAY AREA, SIZE, ORIENTATION, AND LOCATION OF ALL EXISTING UTILITIES, EQUIPMENT, AND SITE FURNISHINGS PRIOR TO ORDERING. SLIDES SHOULD NOT FACE THE HOT AFTERNOON SUN.

CHOOSE A PROTECTIVE SURFACING MATERIAL THAT HAS A CRITICAL HEIGHT VALUE TO MEET THE MAXIMUM FALL HEIGHT FOR THE EQUIPMENT (REF. ASTM F1487 STANDARD CONSUMER SAFETY PERFORMANCE SPECIFICATION FOR PLAYGROUND EQUIPMENT FOR PUBLIC USE, SECTION 8 CURRENT REVISION). THE SUBSURFACE MUST BE WELL DRAINED. IF THE SOIL DOES NOT DRAIN NATURALLY IT MUST BE TILED OR SLOPED 1/8" TO 1/4" PER FOOT TO A STORM SEWER OR A "FRENCH DRAIN".

DESIGNED BY:

COPYRIGHT: 9/3/2015
 LANDSCAPE STRUCTURES, INC.
 601 7th STREET SOUTH - P.O. BOX 198
 DELANO, MINNESOTA 55328
 PH: 1-800-328-0035 FAX: 1-763-972-6091

Date	Previous Drawing #	Initials



90'-5" TOTAL SQUARE FOOTAGE 4885 SQ.FT.

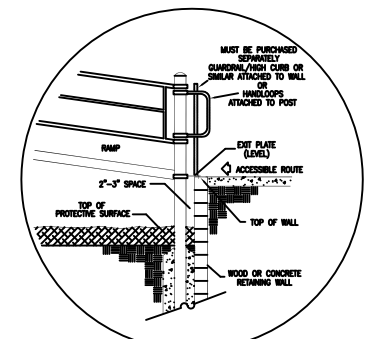

SUGGESTED ELEVATED RAMP EXIT INSTALLATION
 RAMP ELEVATION TO BE ABOVE FINISH GRADE.

THIS DRAWING HAS A THUNDERHEAD AND/OR CLODBURST ON IT, A FREIGHT QUOTE IS REQUIRED

TOTAL ELEVATED PLAY COMPONENTS	31		
TOTAL ELEVATED COMPONENTS ACCESSIBLE BY RAMP	22	REQUIRED	16
TOTAL ELEVATED COMPONENTS ACCESSIBLE BY TRANSFER	31	REQUIRED	0
TOTAL ACCESSIBLE GROUND LEVEL COMPONENTS SHOWN	39	REQUIRED	14
TOTAL DIFFERENT TYPES OF GROUND LEVEL COMPONENTS	28	REQUIRED	27

Estimated manufacturing time:
 4 weeks from the time of LSI order acceptance.

MAX FALL HEIGHT: 96"

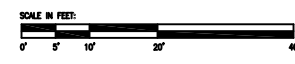

PlayBooster® and Evos® (5-12 years)

Jonesboro Miracle League Park

Landscape Structures

SYSTEM TYPE:
 Playbooster

DRAWING #:
 57619-1-14

